



ALWAYS read these installation instructions carefully before installing this product and leave with the end user.

ALWAYS match the correct waste to the shower base.



ALWAYS have the pumped waste installed by a trained and experienced skilled craftsman.



NEVER use the pumped waste without the unit fully assembled.



DO NOT place matches or cigarettes on or near this product. The following plastic materials are used in this product:
Acrylonitrile Butadiene Styrene (ABS),



BEWARE A child finger trap may be present during the handling or use of this product.



ALWAYS Keep fingers clear of the gaps between the cover, and the locking ring.

15mm or 22mm PGTF Pumped Waste Installation And User Care Instructions John Guest Speedfit* Adaptor

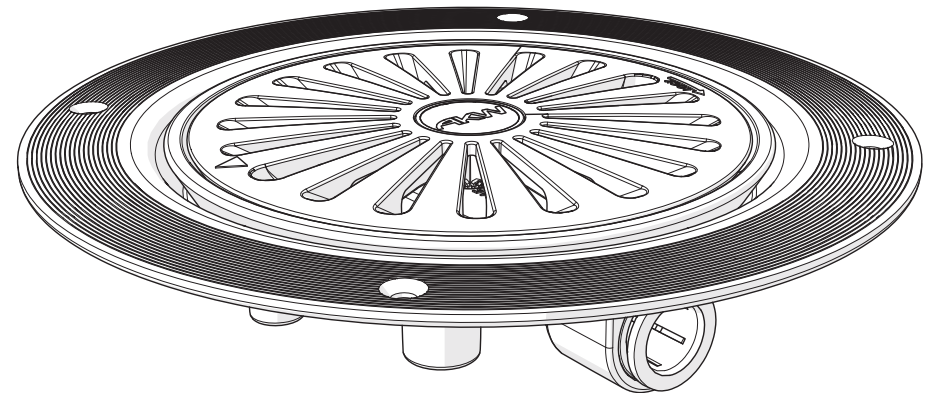

*John Guest and Speedfit are registered trade marks of John Guest International Limited
*Polypipe is a registered trademark of Polypipe plc, a subsidiary of IMI plc.

Failure to install this AKW MediCare product in accordance with supplied instructions or the making of unauthorised modifications will invalidate any warranty and will affect product safety.

The measurements throughout these installation and user care instructions have been converted from metric to its equivalent in imperial, therefore all dimensions are approximate and subject to manufacturing tolerances. This information is furnished upon the condition that the person receiving it shall make his/her own tests to determine the suitability thereof for his/her particular purpose.

AKW Medi-Care Limited, Liberty House, Pointon Way, Hampton Lovett, Droitwich Spa, WR9 0LR
Tel. +44 (0) 1905 823298 - Fax. +44 (0) 1905 823297 - www.akw-medicare.co.uk

Colour: White Internal Building use only

Registered Design/ Patent GB 2373515

Installer: Please ensure that this information is left with the end user of this product.

For full waste specifications see the current AKW MediCare catalogue.

Installation Instructions

Before installation, ensure the former and waste are correctly supported from below and check the wet floor area slopes correctly towards the waste and the waste pipe is laid in the shortest distance to the pump.

Push the deburred end of a Polypipe*, plastic equivalent or suitably protected copper pipe (not supplied), firmly into position following all the normal JG Speedfit assembly precautions and instructions;

Fit the JG adaptor locking ring "2" (supplied);

Position the PGTF and Tuff Form into the required location with the waste drain pipe suitably routed.

Apply sealant to the underside of outer rim and install into the centre hole of the Tuff Form Former. Use 4 CSK Head screws (3) to secure the PGTF in place. Ensure the screw heads are flush and do not protrude or they may damage the wet floor covering.

This sequence can be changed to suit your installation requirements.

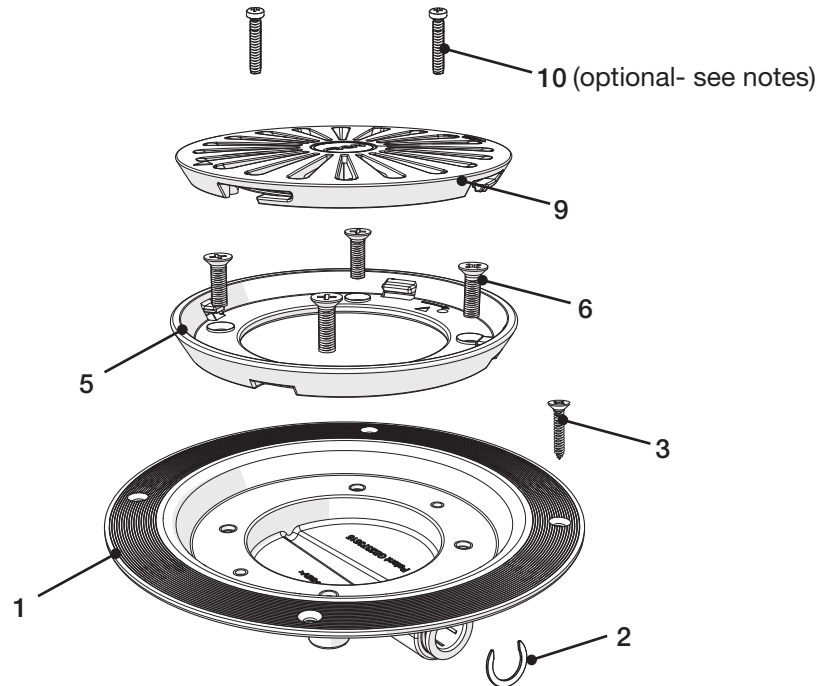

Install the wet-floor covering ensuring all of the manufacturer's instructions are followed. Trim the wet-floor covering to fit the PGTF opening and align and fit the clamp ring (5) with qty 4 M6 stainless steel screws (6).

Position the grid cover (9) over the assembly, align the arrows and rotate the cover clockwise until the lugs snap into place.

For added security remove the two screw knock-outs and fasten the cover using the Qty 2 M4 stainless steel screws (12).

User Care Instructions

This PGTF waste is designed for low maintenance and reliable operation.

The Pumped waste should be checked as part of a planned maintenance programme and any parts showing evidence of damage or misuse must be replaced.

Keeping your pump waste clean

This product should be cleaned periodically to remove any accumulation of hair or other waste material, using normal domestic bathroom cleaning materials.

Clean these parts using warm soapy water. Also flush and wash down the inner body of the trap in the floor using warm soapy water or normal domestic bathroom cleaning materials.

To clean, First remove the top cover by removing the two M4 screws (if fitted), rotate the cover anti-clockwise and lift off.

If necessary the waste can now be rodded to clear any blockage or waste material. Reinstall following the above instructions.

Disinfecting

Where disinfecting is necessary, standard established procedures for disinfecting equipment should be used taking due care and attention to the warnings below concerning possible effects of aggressive chemicals on plastics.

After cleaning always flush down with water then wipe thoroughly with a damp cloth to remove any cleaning material residues before drying off.

Do not use strong or concentrated acidic or alkaline cleaning materials as these may discolour or otherwise damage the product.

AKW do not approve or recommend autoclave cleaning of any of the components due to the damage this can cause to the special engineering plastics used in the construction of this product.

Packaging

This waste is supplied in a plastic bag to keep the product unsoiled until installation; it may also be packed in a cardboard box. Both are suitable for recycling operations and should be disposed of in accordance with local recycling regulations.

